

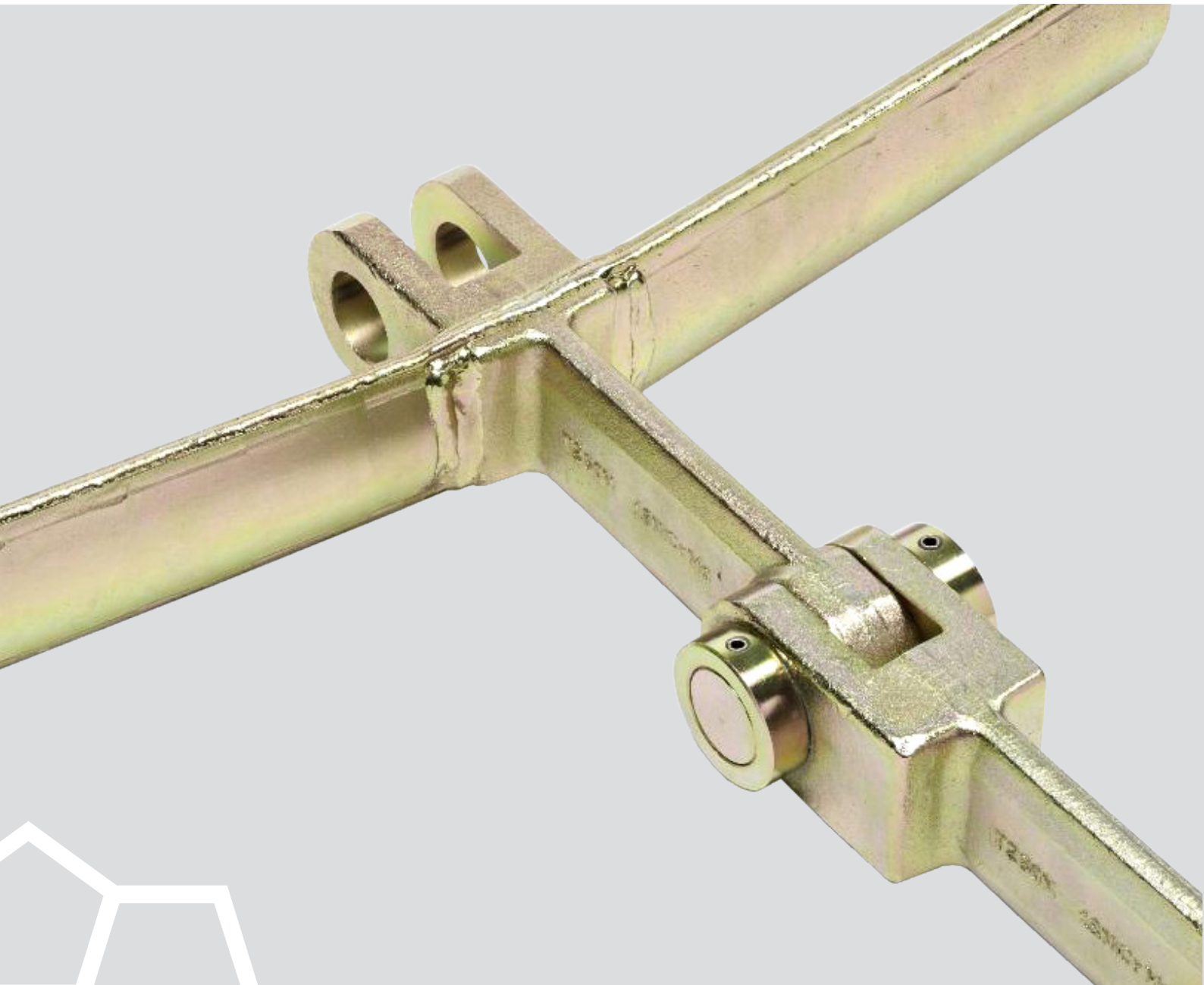

# FB DROP FORGED LINK CHAINS



PREMIUM QUALITY  
CONVEYOR CHAINS  
SINCE 1945

# FB Drop Forged Link Chains for longer lifetime and cost savings.

FB Drop Forged Link Chain works well in challenging environments with different kind of impurities, moisture and heat. The chain is typically used to transport bulk materials and equipped with an application specific scraper. Compatible with other Drop Forged Link Chains on the market (see technical data). Standard parts available in stock. Customized scraper chains within short delivery time.

## FEATURES

---

- hard and durable link material
- good weldability
- extended clearance between the link and pin

## BENEFITS

---

- superior wear resistance, long lifetime
- high impact strength, suitable for rough applications and conditions (e.g. conveying of abrasive materials)
- different type of attachments available
- flexibility of attachment design
- runs well in impure and hot environments

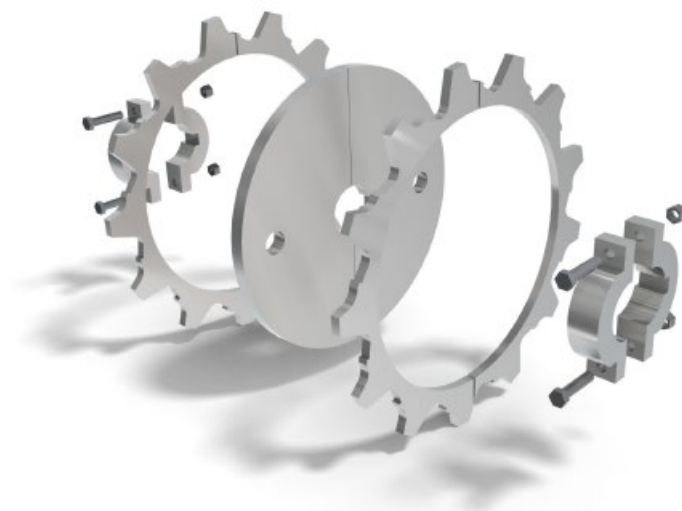

## TECHNICAL DIMENSIONS

Chain	Pitch mm	Width mm	Height mm	Pin Ø mm	Breaking load kN	Weight kg/m
142 N	142	42	50	25	300	9,5
142 V	142	62	50	25	450	14,5
260	260	70	75	40	750	25,2

### FB T142N/T142V Drop Forged Link Chain

Components	Material	Heat treatment	Hardness/HRC
Link 142N	20MnCr5	CH	58 +/-1
Link 142V	20MnCr5	CH	58 +/-1
Pin	18CrNiMo7-6	CH	60 ± 2
Circlip	S235 Zn coated		
Pin	AISI 420	QT+IH	50 ± 2
Circlip	AISI 304		



### FB T260 Drop Forged Link Chain

Components	Material	Heat treatment	Hardness/HRC
Link	17NiCRMo5	CH	58 ± 2
Pin	18CrNiMo7-6	CH	60 ± 2
Locking ring	20MnCr5/CK15	CH	50 ± 2

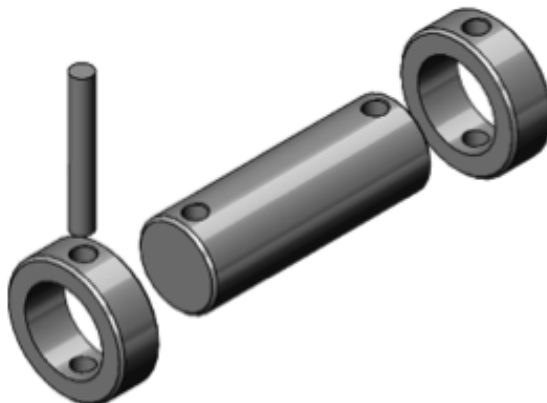

# SPROCKETS AND TRAILERS FOR DROP FORGED LINK CHAINS



## TECHNICAL DATA

Body Structure	Materials
Solid, split	S355, Hardox 400, AISI 304/316

Standard keyways acc. to DIN 6885

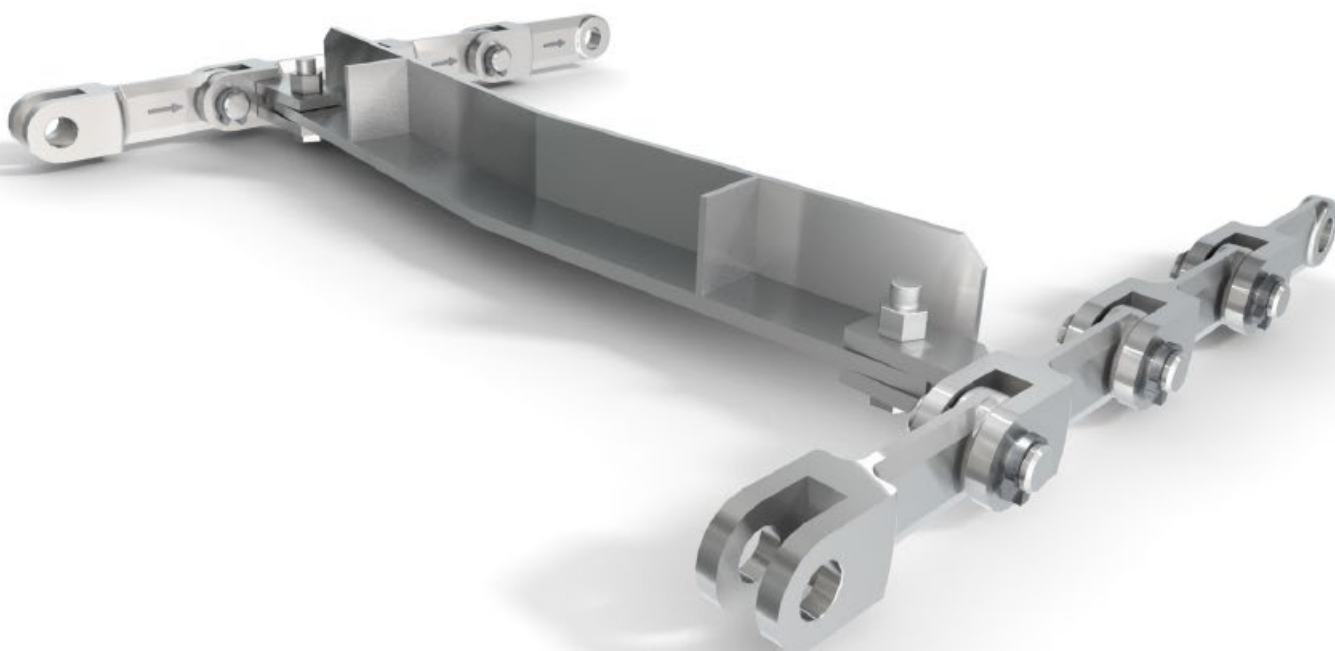

# DIFFERENT FLIGHTS AVAILABLE



Square Bar Flights



Flat Bar Flights

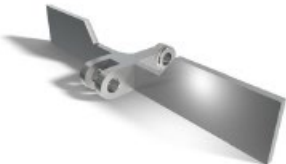

Paddle Flights



U Flights



Closed U Flights



Closed U Flights with Filler Plates



OO Flights



OO Flights with Filler Plates



Double Chains



# FB Ketjutekniikka



PREMIUM QUALITY  
CONVEYOR CHAINS  
SINCE 1945



We have spent many years working with Scandinavia's leading steel producers refining the specialized steels for our conveyor chains.

Our conveyor chains are manufactured using automatic assembly and robotic welders.

**We make the future of conveyor chains.**

FB KETJUTEKNIikka OY  
Kokemäentie 451  
27710 Köyliö, Finland  
tel. +358 207 199 460  
fb@fbketjutekniikka.fi  
www.fbketjutekniikka.fi

ORGANISATION  
CERTIFIED BY

**Inspecta**

ISO 9001  
ISO 14001

